

# TR 4000 Atlas

## Bariatric Shower Trolley



### Specifications

Length	2210 mm (87")
Width	915 mm (36")
Height	535-835 mm (21" - 33")
Working Load Limit	450 kg (1000 lbs)
Chassis	Powder coated and zinc plated steel
Castors	Brakes on all four castors and straight steering
Control	Hand control for height adjustment and tilting
Mattress, pillow	Flame retardant material
Battery	Rechargeable, 24 V



Registered at Medical Products Agency, Sweden, as a MD Class 1 product, MDD 93/42EEC.

## The Atlas Bariatric Shower Trolley - Multi Tasking - Endless Possibilities

The TR 4000 Multi Tasking Shower Trolley is designed for lots of power and loads of space for your most difficult care takers. The trolley is used for shower, transport, as a changing or treatment trolley, the possibilities are endless.

The person can be transferred from bed to shower and back again in a safe and secure manner. The height of the base allows mobile sling lift transfers. Rechargeable battery powered dual actuators raise and lower the stretcher easily and quietly with an easy to use hand control. The hand control operates the power tilt in both directions for improved drainage and tilts to a "Trendelenburg" position when desired. An audible tone sounds when the stretcher is level.

The side rails keep the person safely in place. Side rails swing down for transfer and lock into up position for persons safety and a secure transport. The trolley has central foot operated castor brakes and straight steering. For a tall person the head end rail can be folded to a horizontal position for extra length. The stretcher has two positions, flat for transfer, tilt for transport, shower and improved drainage. The TR 4000 is delivered with a mattress, high capacity rechargeable batteries, hand control, drain plug and hose.



Side rails swing down or lock in horizontal position for transfer and up position for transport.



Head end rail folds to horizontal position for extra length.

### TR EQUIPMENT

TR EQUIPMENT AB

PO Box 116, S-573 22, TRANÅS, SWEDEN

Phone: +46 140-38 50 60

Fax: +46 140-38 50 61

TR GROUP INC.

2990 NORTH PERRYVILLE RD, SUITE 2300, ROCKFORD, IL 61107, USA

Phone: +1-800-752-6900

Fax: +1 815 633-0549

TR EQUIPMENT UK LTD.

INNOVATION CENTRE, GALLOWS HILL, WARWICK CV34 6UW ENGLAND

Phone: +44 844 335 8386

Fax: +44 844 335 8383

TRANSPORHAMED GMBH

GRÜNBAUMSTR. 89 42659 SOLINGEN. GERMANY

Phone: +49 (0) 212-645850-0

Fax: +49 (0)212-645850-50

*Hygiene Equipment Designed for People*

[www.trequipment.com](http://www.trequipment.com)



# TR 4000 Atlas

## Bariatric Shower Trolley



### Features

The stretcher is easily and quietly raised by two powerful actuators. The hand held control operates the power tilt in both directions and raises and lowers the trolley.

The stretcher can be easily tilted to the "Trendelenburg" position, to alleviate a person in shock. The adjustable stretcher enables a comfortable working height for the attendant. An audible tone sounds when the stretcher is level. When transporting through narrow doorways the side rails can be folded reducing the stretcher width.

The stretcher has rubber bumper wheels on all four corners to protect walls and doorways. Stretcher comes standard with a soft flame retardant mattress with drainage at the foot end and includes a drain hose.

The trolley is made of durable material, powder coated and zinc plated steel, making cleaning simple and efficient. Mattress is easily removable.

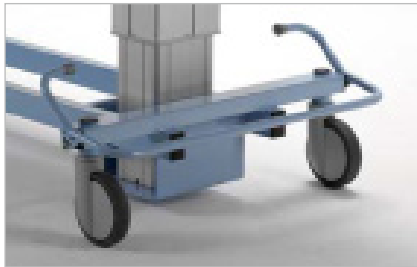

Convenient single foot control for straight steering and brakes.

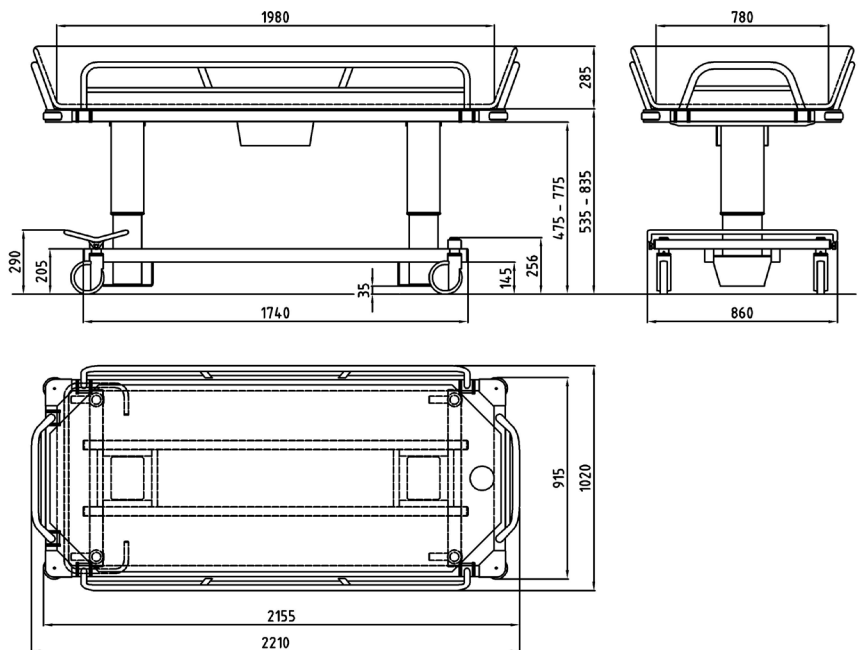

### Accessories

- Backrest wedge pillow
- Backrest wedge pillow 15°
- Backrest wedge pillow 30°

TR reserves the right to make design changes and/or improvements without notice

Distributor:

Manufacturer: TR Equipment AB

### TR EQUIPMENT

TR EQUIPMENT AB

PO Box 116, S-573 22, TRANÅS, SWEDEN

TR GROUP INC.

2990 NORTH PERRYVILLE RD, SUITE 2300, ROCKFORD, IL 61107, USA

TR EQUIPMENT UK LTD.

INNOVATION CENTRE, GALLOWS HILL, WARWICK CV34 6UW ENGLAND

TRANSPORHAMED GMBH

GRÜNBAUMSTR. 89 42659 SOLINGEN. GERMANY

Phone: +46 140-38 50 60

Phone: +1-800-752-6900

Phone: +44 844 335 8386

Phone: +49 (0) 212-645850-0

Fax: +46 140-38 50 61

Fax: +1 815 633-0549

Fax: +44 844 335 8383

Fax: +49 (0)212-645850-50

Hygiene Equipment Designed for People

[www.trequipment.com](http://www.trequipment.com)

